

SCLR

TECHNICAL SPECIFICATIONS:

- :: 4 Feet long
- :: No tandem connection
- :: Voltage: 120-277VAC 50/60Hz
- :: Wattage: 40W
- :: Ambient Temperature: -13°F~104°F
- :: Dimmable: 0~10V dimmable
- :: CRI:>80
- :: Power Factor:>0.95
- :: Efficacy: 110LM/W
- :: IP Rating: IP20
- :: Life Span: 50,000 hours
- :: Housing: White, Die-cast Aluminum
- :: Lens: Prismatic Polycarbonate
- :: 5-year warranty

B1



Optional Accessories (See Page B34)



6 Ft. Cord
SJTW 18 AWG 5-Conductor
(Not Included)



Adjustable 6 Ft.
Suspension Kit
Select a Single-
Connector Key Hole Set
(Not Included)

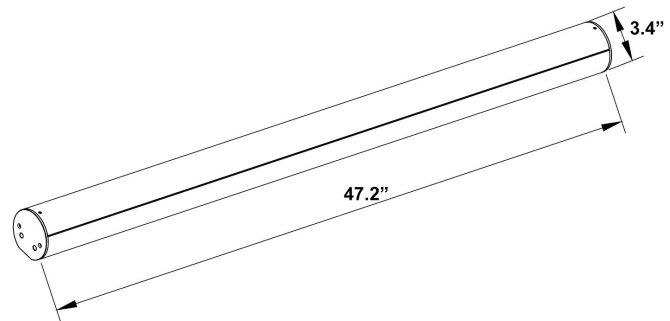

LED ARCHITECTURAL ROUND SUSPENDED LIGHTS

CATALOG NO.	WATTS	LUMENS	COLOR TEMP	DIMENSIONS
SCLR-4FT-40W-50K-D	40W	4400LM	5000K	47.2"(L) x 3.4"(W) x 3.4"(H)
SCLR-4FT-40W-40K-D	40W	4400LM	4000K	
SCLR-4FT-40W-35K-D	40W	4400LM	3500K	